

**Description (Sample Specification Language)**

The Gastite<sup>®</sup> Gas Load Center creates a recessed cabinet for more polished looking manifold assemblies. The Gas Load Center is capable of organizing and securing multiple Gastite runs, manifold, union, small regulator, drip leg, and shut-off valves. For assemblies requiring a union, valve, bonding clamp, or regulator, this provides a recessed mounting option while allowing code required accessibility. (Check local codes to determine what is required for an approved manifold or regulator assembly).

**Features:**

- Quick & Easy Installation
- Fits within 16" on center wall cavities.
- Used on steel and timber framing
- Provides a secure manifold assembly.
- Vertical channels for variable bracket positioning.
- Includes labeling sticker for gas run information.
- Six knockouts top and bottom.
- Kit Contains: mounting box, trim flange, manifold bracket and mounting hardware.
- Optional louvered panel shown below.
- For use with manifolds 3-PORTMAN, 3-PORTMAN-1 and 4-PORTMAN

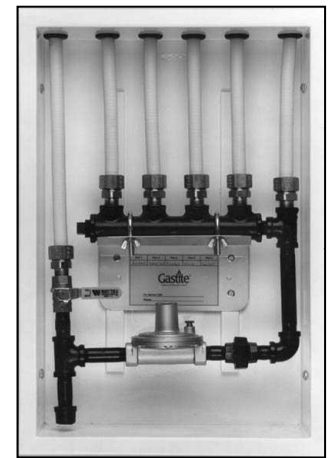

**Technical Data:**

General:

Box Material	20 Gauge Steel
Box Color/Coating	White/Polyester Powder coat
Manifold Bracket	MBRACE-2 (Secures 1.06"-1.30" OD Pipe)
Bracket Material	16 Gauge Galvanized Steel
Hardware Included	2 x 5/16" U-bolt – Coarse Thread 4 x 5/16" Wing Nuts – Coarse Thread

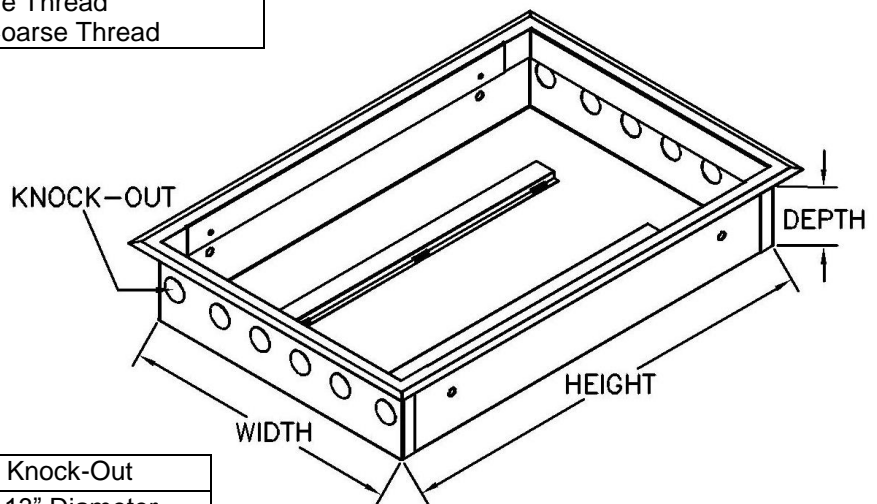

**Dimensional Characteristics:**

P/N	Width	Height	Depth	Knock-Out
GLC1	14-1/2"	22"	4"	1.13" Diameter