

Description:

XR3 series mechanical brass fittings are specifically designed for use with Gastite® and FlashShield™ flexible gas piping systems complying with ANSI LC 1 "Fuel Gas Piping Systems Using CSST". The self-flaring fitting produces a metal-to-metal seal, and is reusable. The fittings have standard NPT threads and may be used in combination with all approved fuel gas piping materials with pipe thread as an interface. The Jacket-Lock™ and Shield-to-fitting features provide CSST protection.

Components:

- Fixed Point Termination with Female XR3 Fitting

Features:

- Tool-Less Flare Fitting Design
- Metal-to-Metal Seal
- Multi-Point Seal
- Jacket-Lock™
- Shield-to-fitting
- Fully Reusable Fitting
- Approved for Outdoor and Concealed Use

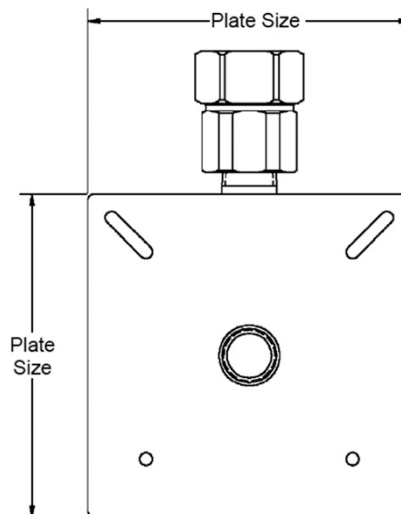

Applicable Standards & Listings:

- CSA: Certificate No. 2728525
- ICC-ES Report No. PMG 1155 and PMG 1019
- IAPMO: File No. 3250 and Report No. 0239

Technical Data:

General

Max. Approved Operating Pressure	25 psi
Operating Temperature Range	-40°F to 160°F
Fitting Material	CA360 Brass
Stub-Out Material	Sch 40 Steel pipe E-Coat

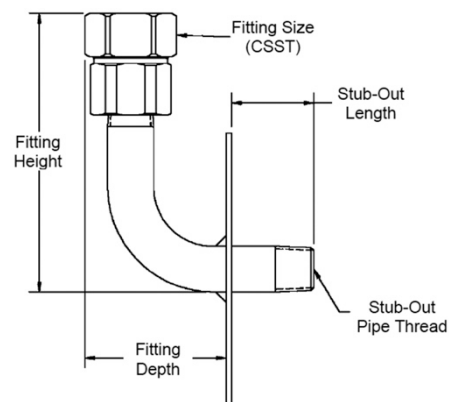

Dimensional Characteristics

P/N	Stub-Out Length	Fitting Depth	Fitting Height	Stub-Out Pipe Thread	Fitting Size (CSST)	Plate Size	Reference Assembly Torque (ft-lbs)	Weight (lbs)
XR3-APSTUB-8	1-1/2"	2-1/2"	5-1/4"	1/2"	1/2"	5"	35	1.49
XR3-L-APSTUB-8	2-1/4"	2-1/2"	6"	1/2"	1/2"	5"	35	1.55
XR3-APSTUB-11	1-1/2"	2-3/4"	5-1/4"	1/2"	3/4"	5"	45	1.91
XR3-L-APSTUB-11	2-1/4"	2-3/4"	6"	1/2"	3/4"	5"	45	1.97
XR3-APSTUB-11-11	1-1/2"	3-1/4"	6"	3/4"	3/4"	5"	45	2.14
XR3-L-APSTUB-11-11	2-1/4"	3-1/4"	6-7/8"	3/4"	3/4"	5"	45	2.20